

Super Power Pusher™

**Battery-Powered
Material Handling**



The ***Super Power Pusher™*** has the push/pull capacity necessary to overcome extremely heavy or high rolling resistance loads, delivering the ability to maneuver virtually any industrial load. Featuring a low-maintenance design and a heavy-duty construction for extreme durability, Super Power Pusher is capable of mobilizing loads reaching up to 250,000 pounds. Plus with its wide range of custom, modular attachments, this device is as flexible as the loads it transports.

Super Power Pusher

FEATURES AND BENEFITS

- 36-volt DC, 1500-watt motor provides 150,000 pounds push/pull capacity
- Dual motor model available that delivers up to 250,000 pounds of push/pull capacity
- Fully programmable control system with diagnostic features to adjust speed and acceleration/deceleration based on load and environment
- Solid rubber wheel drive with alternative tread patterns and materials specification for various floor applications
- Electrically powered with on-board charger for efficient, long-lasting operation
- Fingertip controls and compact construction deliver easy maneuverability
- Automatic braking for improved operator safety



ACCESSORIES

- Ergonomic handles and hand guards for operator comfort and safety
- Strobe and audible motion beeper for safety and visibility on plant floor
- Versatile standard and custom attachment options available



Scan using your mobile app

SPECIFICATIONS

- **Motor type:** 36 Volt D.C. — 1500W
- **Gearbox:** Single speed reduction gearbox, with differential
- **Drive Mechanism:** 2 x chain & sprocket
- **Controller:** Digital fully programmable, with fault diagnostic capability
- **Batteries:** 3 x 90 Ah Dryfit, Gel Type. Sealed & maintenance free
- **Battery Charger:** On-Board, 3 stage, 3 x 15 Amp output 110v or 240v
- **Push/Pull Capacity:** Up to 100,000 lbs. (subject to rolling resistance)

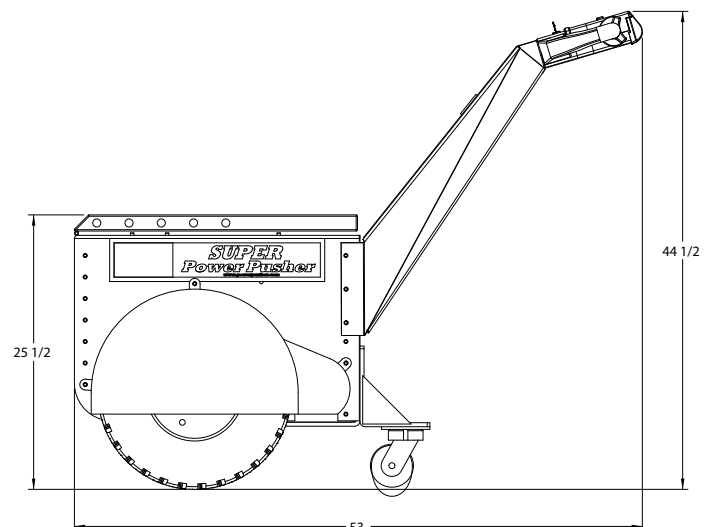

1425 Stagecoach Road, Shakopee, MN 55379
Phone: 800.800.9274 or 952.445.8295
Fax: 952.445.0231

powerpusher.com



PowerPusher®
If It Rolls... We Can Move It.™