

# Power Tug™

Battery-Powered  
Material Handling



The **Power Tug™** is designed to promote productivity and minimal manpower by mobilizing up to 5,000 pounds with ease. Machine is equipped with an electric/hydraulic actuator in order to accommodate various load heights, and its mono-drive wheel with stabilizing caster enables the unit to mobilize loads over uneven surfaces and features varying swivel casters/wheels with complete control.



# Power Tug

## FEATURES AND BENEFITS

- Mono-drive wheel for stable performance on uneven surfaces
- Fingertip controls for operator convenience and ease-of-use
- On-board charger for long-lasting, efficient operation
- Automatic braking and emergency reverse protection improves operator safety
- Fully programmable control system with diagnostic features to adjust speed and acceleration/deceleration based on load and environment
- 24-volt DC, 600 watt motor for 5,000 pound push/pull capacity
- Ergonomic handles for operator comfort
- Compact size for easy maneuverability
- Polyurethane drive wheel outer with alternative tread patterns and material specifications

## ACCESSORIES

- Audible motion beeper
- Safety strobe
- Dual leg configuration
- Custom attachments for versatile applications

## SPECIFICATIONS

- **Motor type:** 24 Volt D.C. —600W (2,500 lbs. capacity), 1200W (5,000 lbs. capacity).
- **Drive Mechanism:** Planetary Gearbox, 18:1 reduction, through mono-drive
- **Controller:** Fully programmable digital, with diagnostic capability, four quadrant full bridge power output stage.
- **Batteries:** 2 x 60 Amp/hour dryfit, gel type sealed and maintenance free.
- **Battery Charger:** On-Board, 3 stage, 2 x 10 Amp circuits (110v or 240v input).
- **Push/Pull Capacity:** Up to 5,000 lbs. (subject to rolling resistance of load).

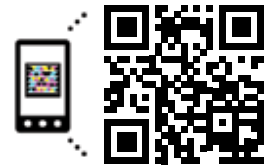

Scan using your mobile app

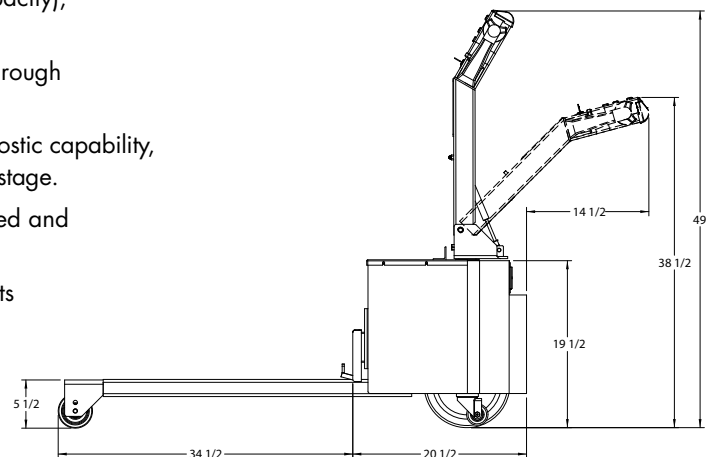

1425 Stagecoach Road, Shakopee, MN 55379  
Phone: 800.800.9274 or 952.445.8295  
Fax: 952.445.0231

[powerpusher.com](http://powerpusher.com)



**PowerPusher®**  
*If It Rolls... We Can Move It.™*