

MFC-100™

Battery-Powered Material Handling



The hydraulically operated **MFC-100™** is ideal for lifting and moving heavy barrels, automotive towing or lifting awkward equipment. With push-button ease, operators can engage the hydraulic lift to raise the load for effortless transportation. Featuring diverse attachment options and a 15,000-pound maximum push capacity, the MFC-100 is a powerful, flexible industrial cart solution for a wide range of material handling applications.

MFC-100

FEATURES AND BENEFITS

- Fully programmable control system with diagnostic features to adjust speed and acceleration/ deceleration based on load and environment
- Fingertip control and compact sizing deliver superior maneuverability
- Load capacity of 15,000 for heavy-duty applications
- Built-in battery charger for long lasting operation
- Automatic braking for increased operator safety

ACCESSORIES

- Crane lift for heavy material handling applications
- Utility table for holding or moving awkward parts or equipment
- Custom, interchangeable attachments for individual requirements

SPECIFICATIONS

- **Motor type:** Hydraulic
- **Drive Mechanism:** Hydraulic
- **Controller:** N/A
- **Batteries:** 2 12 Volt Group 27 Deep Cycle Marine
- **Battery Charger:** Built in battery charger
- **Push/Pull Capacity:** Up to 15,000 lbs.
- **Lifting Capacity:** Dependent on attachment



Scan using your mobile app

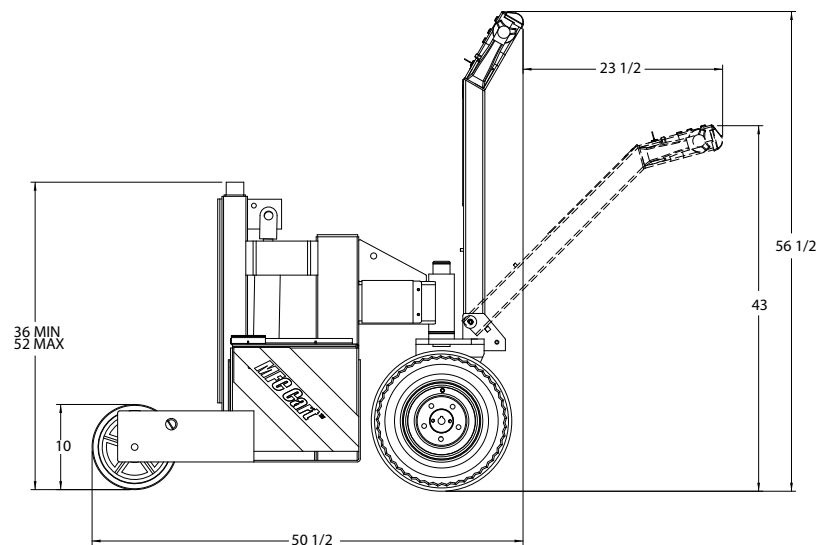

1425 Stagecoach Road, Shakopee, MN 55379
Phone: 800.800.9274 or 952.445.8295
Fax: 952.445.0231

powerpusher.com



PowerPusher®
If It Rolls... We Can Move It.™