

Hazardous Duty Power Pusher™

Battery-Powered
Material Handling



The **Hazardous Duty Power Pusher™**, certified for Class 1, Division 1, Group D areas, is designed to tackle challenging applications in demanding environments. With a temperature classification rating of T4, it can withstand temperatures reaching 135°C. The device pushes or pulls carts, dollies, vats and more, weighing up to 25,000 pounds. Plus, with a wide variety of application-specific attachments available, it can be customized to your requirements for a high-quality, heavy-duty tug for challenging environments.

Hazardous Duty Power Pusher

FEATURES AND BENEFITS

- Class 1, Division 1, Group D certified for use in hazardous locations
- 24-volt DC, 400-watt motor for powerful push/pull capacity of 25,000 pounds
- T4 temperature classification for operation in 135°C
- Rechargeable, fully sealed gel cell marine batteries for long operational life
- Fully programmable control system with diagnostic features to adjust speed and acceleration/deceleration based on load and environment

ACCESSORIES

- Ergonomic handles and hand guards for operator comfort and safety
- Strobe and audible motion beeper for safety and visibility on plant floor
- Versatile standard and custom attachment options available

SPECIFICATIONS

- **Motor type:** 24 Volt D.C. 400W (25,000 lbs. capacity)
- **Gearbox:** Single speed reduction gearbox, with differential
- **Drive Mechanism:** 2 x chain and sprocket
- **Controller:** Fully programmable, with diagnostic capability
- **Batteries:** Sealed, gel cell marine batteries
- **Battery Charger:** Stand-alone, 3 stage, 2 x 10 Amp circuits
- **Push/Pull Capacity:** Up to 25,000 lbs. (subject to rolling resistance of load)



Scan using your mobile app

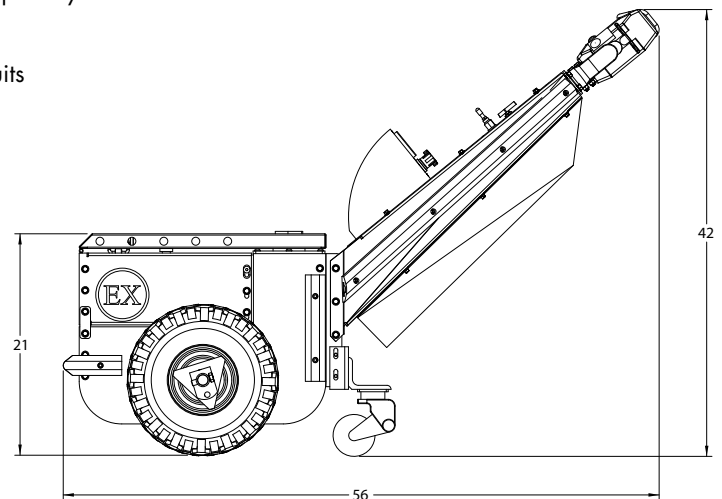

1425 Stagecoach Road, Shakopee, MN 55379
Phone: 800.800.9274 or 952.445.8295
Fax: 952.445.0231

powerpusher.com



PowerPusher®
If It Rolls... We Can Move It.™